

CVD

Batch Processing

Engineering

Lab Services

Maintenance Services

Manufacturing

CVD

Continuous Variable Discharge Technology

Providing Unique Processing Solutions to the World



Continuous Variable Discharge Technology

Employing proven fluidized bed technology from the Knelson Concentrator family of products, Knelson now offers the CVD (Continuous Variable Discharge Concentrator Technology).

The CVD technology was specifically developed for applications where the mass yield to concentrate is greater than can be processed with traditional batch concentrator technology.

The CVD will discharge concentrate while simultaneously processing fresh feed, allowing mass yields from 0.1% to 50%. Due to the continuous discharge of the concentrate and the high processing capacity of the CVD, the technology offers enhanced gravity separation for the processing of ores with a relatively high content of target mineral.

Continuous Variable Discharge Operation

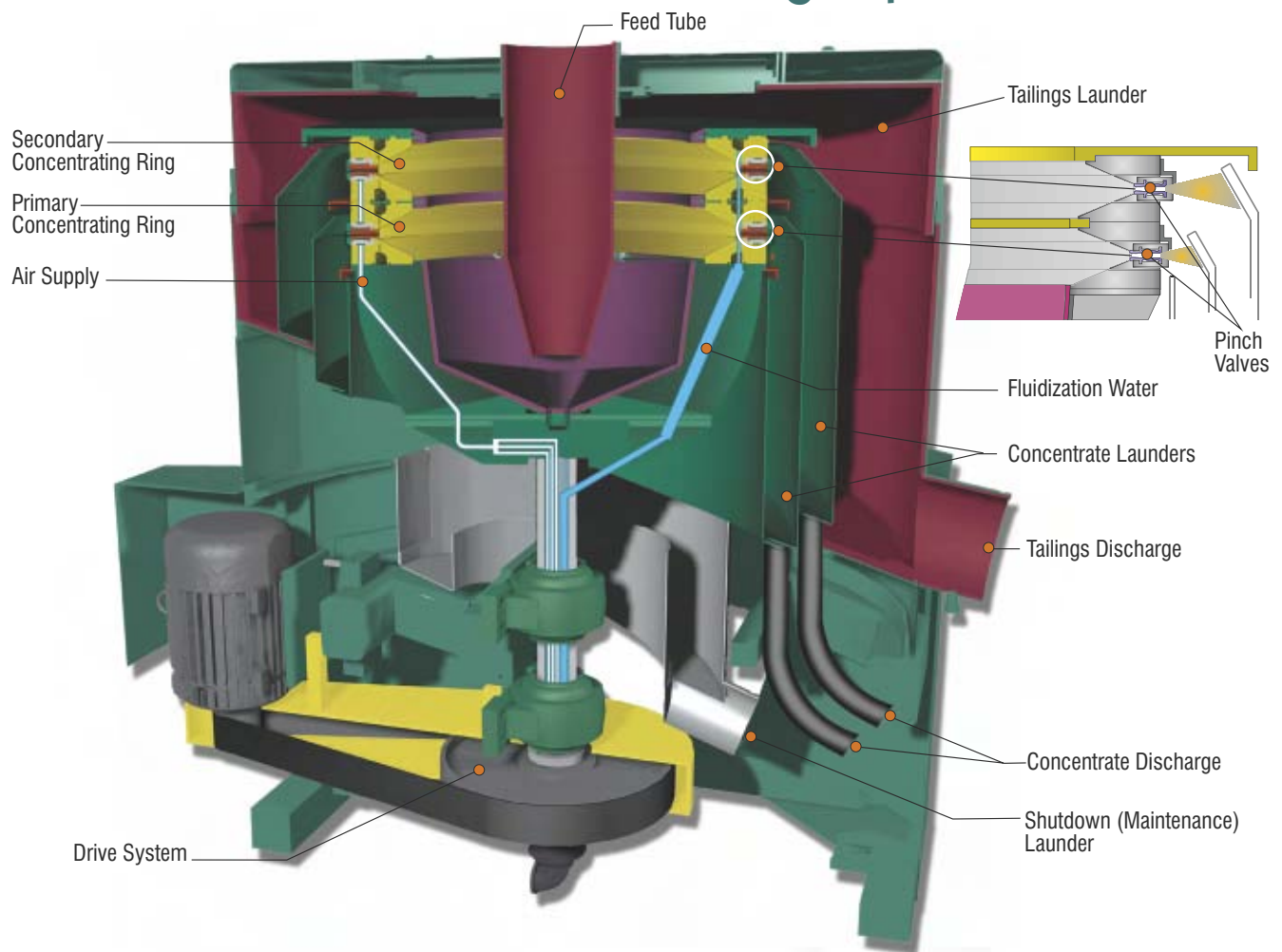

1. Water is introduced through a series of fluidization holes located in the concentrating ring(s).
2. Feed slurry is introduced through the central feed tube.
3. When the slurry reaches the bottom of the cone it is forced outward and driven up the cone wall toward the concentrating ring(s).
4. The slurry fills the concentrating ring(s) to create a fluidized concentrating bed.
5. The fluidization water allows heavier particles to be preferentially recovered in the concentrating ring(s).
6. Pinch valves are actuated, allowing concentrates to be drawn from the concentrating ring(s) at a controlled rate. Pinch valve actuation time can be varied, thereby enabling independent adjustment of mass yield from each ring.
7. Concentrates report to dedicated launder(s) while tailings flow out the top of the cone into the tailings launder.

Features and Benefits of the CVD Technology

Features

- CVD Concentrators are designed using many of the same components as Knelson's batch concentrators
- All surfaces in contact with slurry are manufactured using high wear resistance materials (urethane, Linatex)
- Operation is fully automated
- All operating variables are field selectable (fluidization water flow, g-force, mass yield) using Knelson's proprietary "Independent Control System" (ICS)
- CVD Concentrators are available in one and two ring models. Two ring models can collect separate concentrates from each ring
- Fluidization water ensures that feed, concentrate and tails flow smoothly
- Fluidization water effectively de-slimes most feeds
- CVD Concentrators offer high capacities relative to their footprint and can be easily retro-fit in most existing plants



Benefits

- Components used in manufacture are well proven in many years of successful applications in mineral processing environments
- CVD Concentrators are designed for long life, high machine availability and minimal downtime
- Operating parameters can be optimized for individual application
- Separate concentrates from each ring can be treated individually for better metallurgical efficiency
- Feed, concentrate, and tails are not subject to plugging, bridging or packing, as can happen with the dewatering effect of unfluidized enhanced gravity systems
- Large amounts of very fine gangue materials can render other forms of gravity treatment ineffective. CVD Concentrators can pre-concentrate and de-slime many feeds, thereby enhancing downstream processes



Typical CVD Applications

The Knelson CVD Concentrator can generally be used to separate any minerals where the specific gravity difference between the target mineral and the background gangue is 1.5 or greater. These include the following:

- ◆ Tantalite recovery
- ◆ Cassiterite recovery
- ◆ Ilmenite/Rutile recovery
- ◆ Iron removal from industrial minerals
- ◆ Chromite recovery
- ◆ Gold sulphide recovery from leach or flotation tailings
- ◆ Ferroalloy (alloy from slag) applications
- ◆ Pre-concentration of heavy mineral sands
- ◆ Pre-concentration and de-sliming of heavy minerals

How to Determine if the CVD is Suitable for Your Application

A three step process

1. Complete our CVD application questionnaire.

This will give us some basic information on your process and will allow us to make a preliminary determination as to whether the CVD is suitable for your application. The questionnaire is on our website at www.knelson.com, or is available from your local Knelson Representative.

2. Send us a 5 kilogram sample.

We will use this sample to perform a gravity amenability test, and to develop some baseline information on your ore.

3. Pilot plant test.

Based on the results of the gravity amenability test described above, the next step may be to test your sample at one of our designated pilot facilities strategically located throughout the world.

In the pursuit of excellence, there is no substitute for innovation, dedication and integrity. By applying these values to our everyday working lives, Knelson has become the undisputed industry leader, providing our clients with a quality of product and service which consistently exceeds their expectations.

Knelson is a Canadian-based company specializing in the research and manufacture of process equipment. The company is comprised of several divisions, all specializing in unique processing solutions.



Knelson Concentrators (KC)

Mineral processing equipment used for enhanced gravity separation of gold, precious metals, base metals and industrial minerals.



Knelson Research and Testing Centre Laboratory (KRTC)

Comprehensive gravity amenability testing and assorted process services.



Knelson Engineering and Manufacturing (KEM)

Quality services in engineering and manufacturing for all industry sectors.



KNELSON

19855 - 98 Avenue
Langley, British Columbia
Canada V1M 2X5

Phone: (604) 888-4015

Fax: (604) 888-4013

Toll Free in North America:

1-888-456-3576

Email: knelson@knelson.com

Web site: www.knelson.com